

KORDECKI AUTOMATION Ltd

Connecting scientists and application with physical processes and equipment

Company Presentation for BIG SCIENCE

By Piotr Kordecki – CEO
& Pawel Radwan - CTO



What we do?



***Delivering control system, based on PLC,
for industrial processes, machines and research projects.***



Our service in ICS?

Roughly scope of Integrated Control System for accelerators

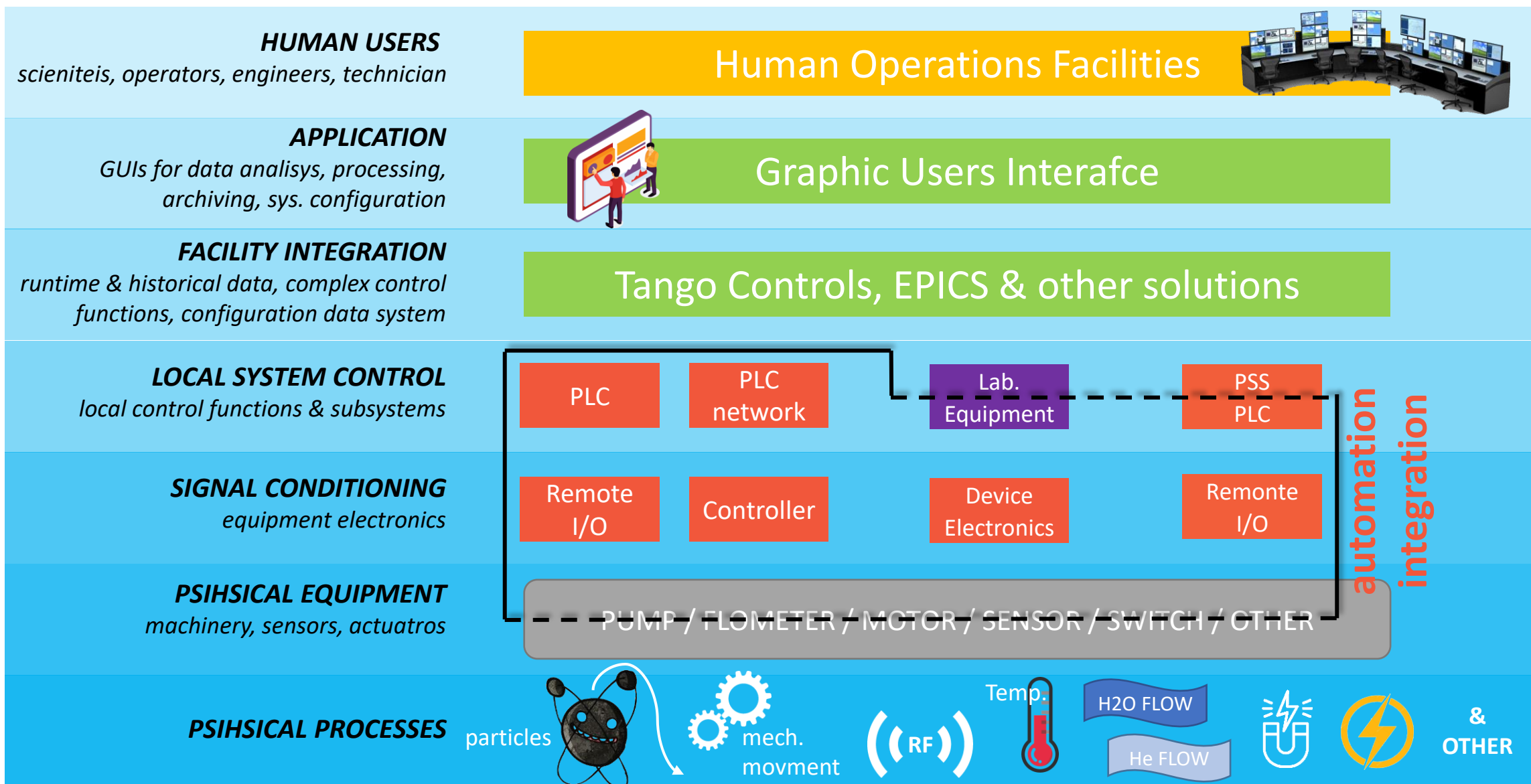

Our approach to customers' needs.

PROBLEMS

- *Delivering quality from for all technology vendors responsibility of on stages*
- *Supplier suppliers & distant time of delivering stages.*
- *From the very beginning we consult each stage of project with customer*
- *No possible complete verification of stages before commissioning*

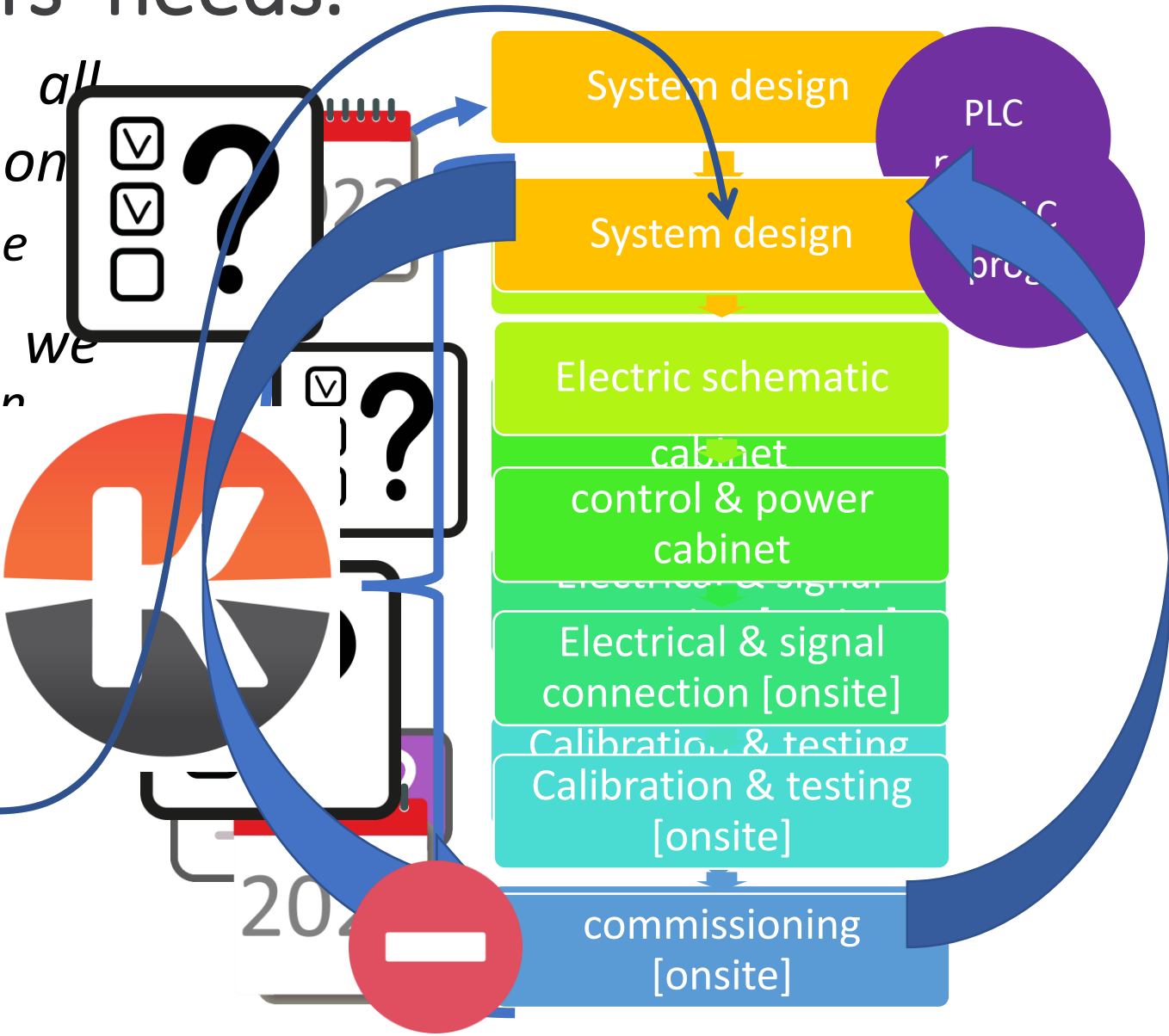

#1 Projects – Control cabinets prefabrication for ESS

- *Project review*
- *Design improvement*
- *Prefabrication of control cabinets*

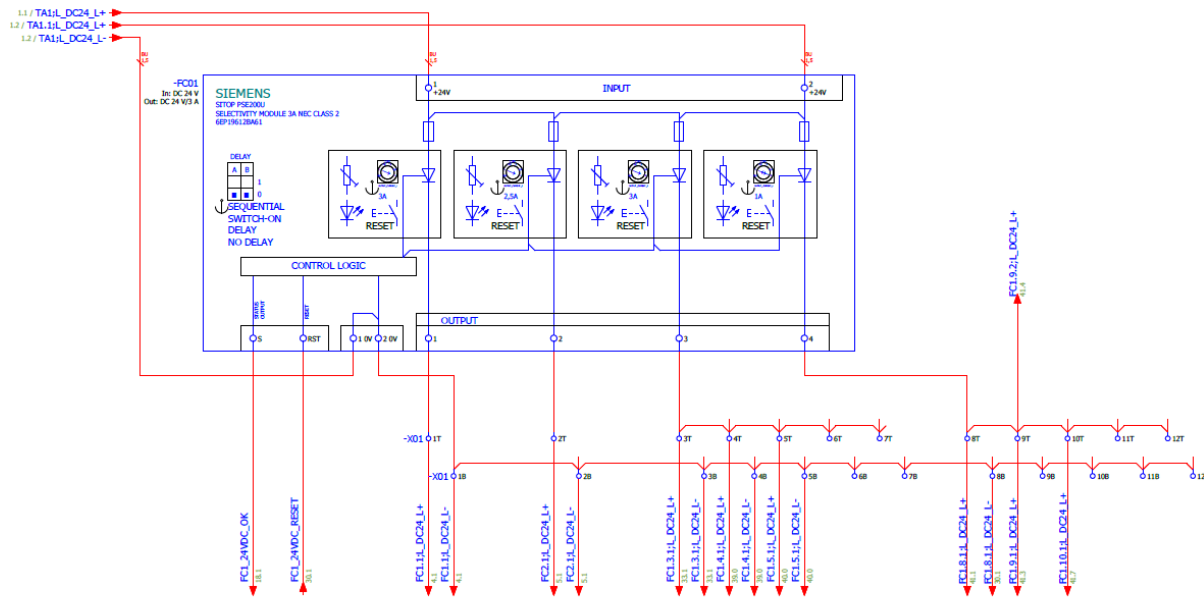

#2 Projects – Connection of automation system for cryogenics in ESS

- *Cables measurements*
- *Connections*
- *Loopchecks*
- *System commissioning
(in the future 2022)*

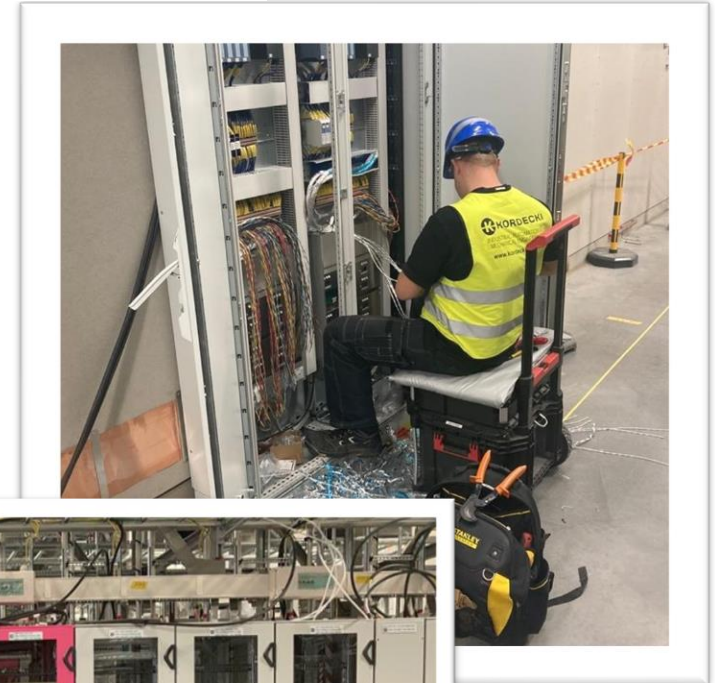
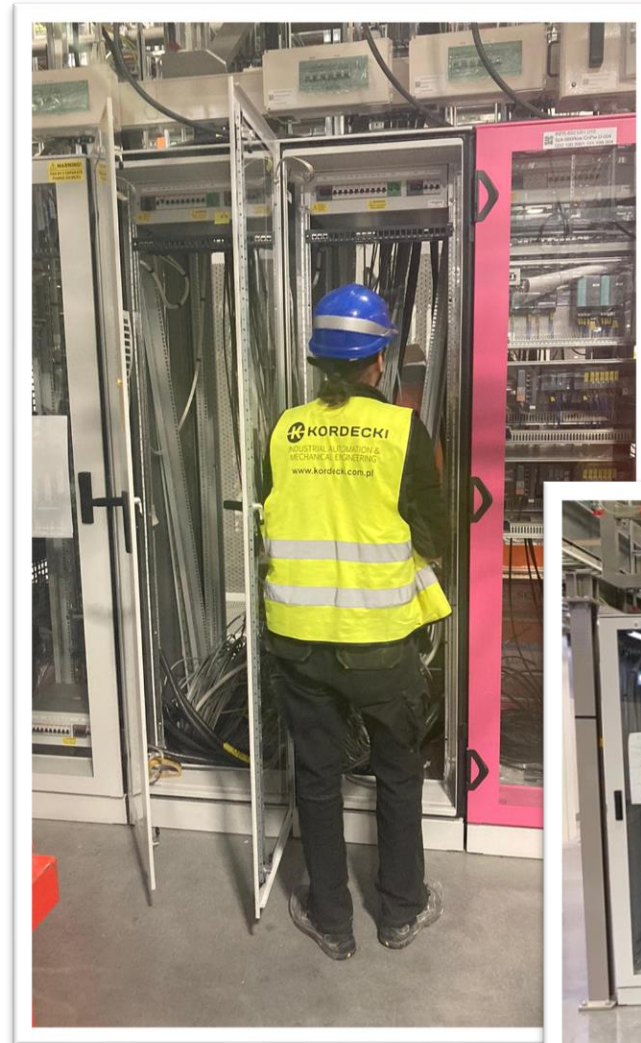
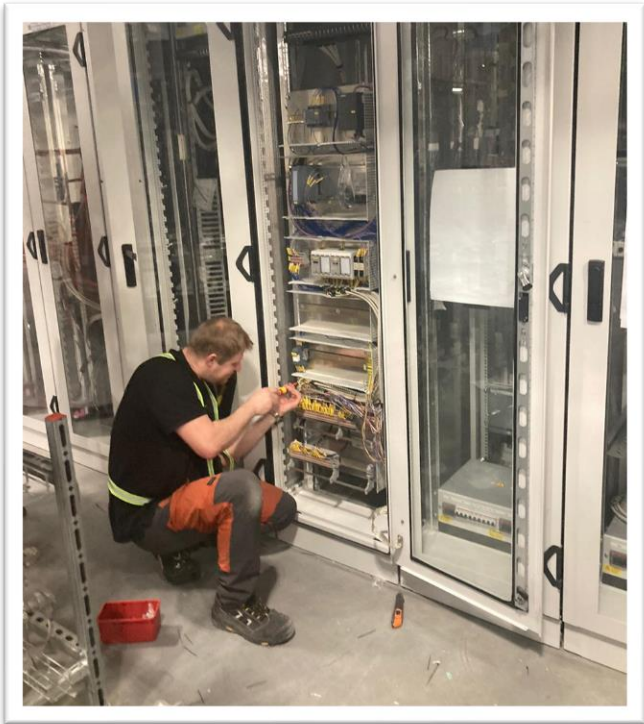

#3 Projects – Customized heaters drivers system for Cryomodule in ESS

- Design consultation
- System project
- controller design in cooperation with another company
- Control cabinet prefabrication
- System connection
- System calibration
- System commissioning
- System testing in TS2 (in progress)

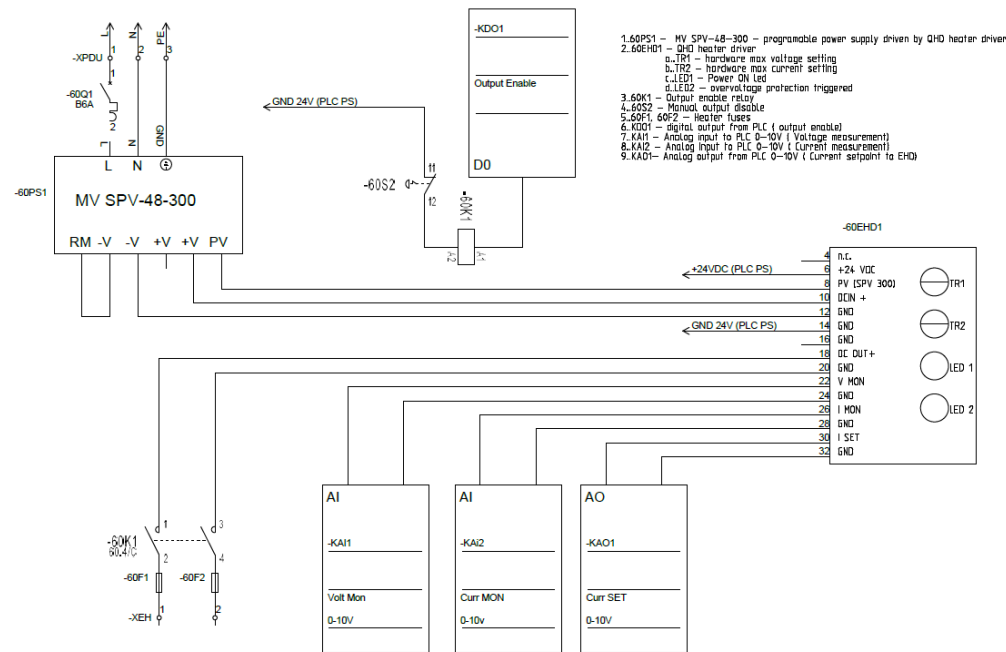

#4 Other examples of projects – for industrial processes

- *Garbage sorting [writing a software for PLC based on customer's demands]*
- *Volatile organic compound (VOC) afterburner [writing a software for PLC based on customer's demands]*
- *Drying installation - delivery of the complete control system [8MW steam power, energy recovery system, 200kW of fans, a lots of drivers]*
- *Retooling and reprogramming production line [over than 30 production stations] for leading production company in automotive*



Competences

- *Automation project consultations*
- *Designing of automation systems*
- *Drawing electrical diagrams*
- *Prefabrication of Control and Power cabinets*
- *PLC programing & LabView*
- *System testing calibrations*
- *Automation systems commissioning*
- *Solving problems in the operation of autoamation systems*

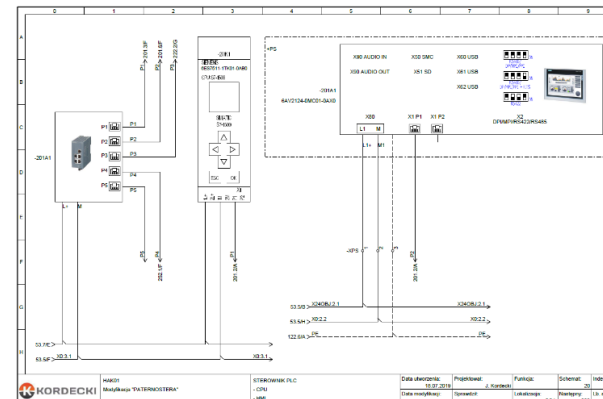

About company

- *Basic information*
- *Poland, Wroclaw, Technology Park*
- *Our TEAM*

- **2015' - established**
- **11 employees – regular stuff.**



the peak.

Poland.

specialists **WPT**
WROCLAW TECHNOLOGY PARK

electronics



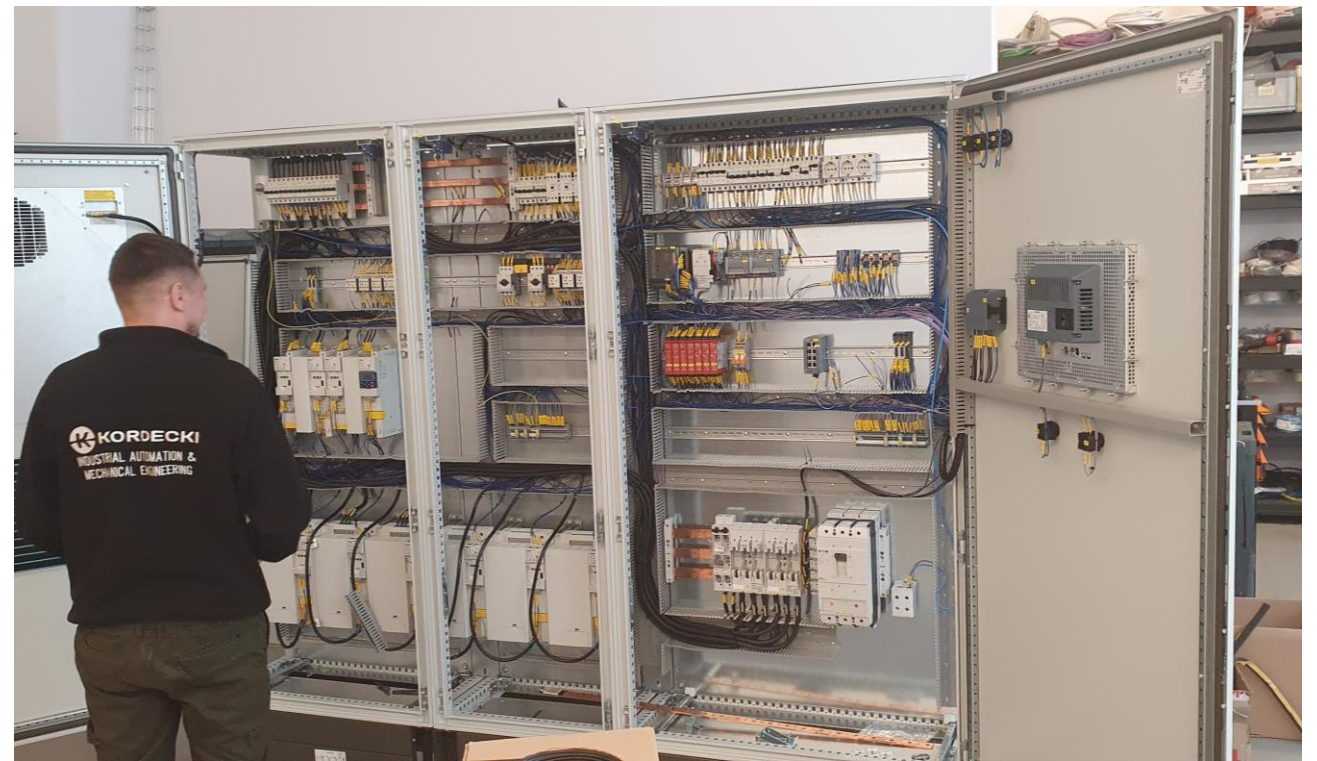



OUR CUSTOMERS AND END USERS



KORDECKI AUTOMATION Ltd

Connecting scientists and application with physical processes and equipment

We appreciate your feedback and questions!
Thank you for your time!

Piotr Kordecki – CEO

0048 502 501 136

p.kordecki@kordecki.com.pl

Pawel Radwan – CTO

0048 791 592 309

Pawel.radwan@kordecki.com.pl